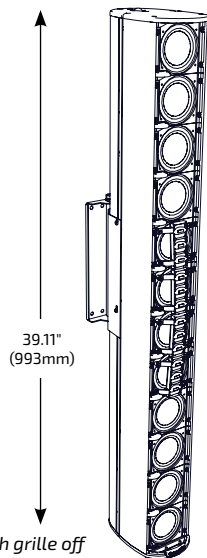

E SERIES
 Point Source

ENT212

 TWO-WAY, COMPACT
 COLUMN ARRAY LOUDSPEAKER

APPLICATIONS

Houses of Worship · Bars and restaurants
 Meeting rooms · Conference rooms · Court rooms
 Auditoria · Theaters · Museums · Airports
 Stadium concourses · Gymnasiums, athletic facilities
 Multipurpose outdoor and indoor venues

DESCRIPTION

Available in four sizes, the ENTASYS 200 models have been expertly engineered to serve the wide range of applications routinely encountered by professional sound contractors. Possessing advanced features, highly-focused dispersion patterns, weather-resistant construction, and most importantly sonic excellence, ENTASYS 200 columns make installations not only fast and simple, but as functionally effective as possible.

The ENT212 is an all-weather column line array housed in an attractive, heavy duty extruded PVC enclosure. Twice the height of the ENT206, the ENT212 provides vertical directional control at far lower frequencies than the ENT206, plus enough power to cover medium-sized venues as the primary system. The ENT212 employs twelve high-power LF cone drivers and four Community CRE (Compact Ribbon Emulator) HF tweeter arrays in a single-amped configuration that employs a 4-way frequency shaded crossover.

The ENT212 excels in noisy environments - gymnasiums and other athletic venues are just two of many examples - while its high-fidelity response makes it suitable for more subtle applications such as scholastic auditoriums, houses of worship, jazz and folk music clubs, corporate AV presentations, and much more. The excellent vertical directivity conquers large, reverberant spaces, providing excellent intelligibility and musicality. With the addition of subwoofers, an ENT212 system is capable of meeting a vast range of requirements, from the soccer stadium to the performing arts center.

FEATURES

- Advanced passive crossover technology and dynamic protection circuitry
- Compact Ribbon Emulator high frequency technology for narrow, well-behaved vertical directivity control
- All-weather construction for indoor/outdoor usage
- Simple installation using the included pan-tilt mounting bracket
- Selectable low impedance or 70V/100V operation

TECHNICAL SPECIFICATIONS¹

Operating Mode	Passive		
Operating Environment	Indoor or Outdoor Direct Exposure		
Operating Range²	120 Hz to 22 kHz		
Nominal Beamwidth (H x V)	140° x 15°		
Transducers	LF 12 x 80mm long excursion mylar driver HF 4 x 3-element Compact Ribbon Emulator		
Continuous Power Handling³ @ Nominal Impedance	Passive*	51V	325W @ 8 Ohms (1300W peak)
Autoformer	70V 120W 60W 30W 15W 7.5W	100V 120W 60W 30W 15W	
Nominal Sensitivity⁴	Passive	@ 1W 97 dB	@ 2.83V 97 dB
Nominal Maximum SPL⁵ (Whole Space)	Passive	Peak 128 dB	Continuous 122 dB
Equalized Sensitivity⁶	System	@ 1W 97 dB	@ 2.83V 97 dB
Equalized Maximum SPL⁷	System	Peak 128 dB	Continuous 122 dB
Required Accessories	External High Pass Filter - 100 Hz, 24 dB /octave		
Recommended Amplifiers	Passive	325W - 650W @ 8 Ohms, (51V - 72V)	
PHYSICAL			
Input Connection	NL4-type connector for low impedance operation, and 8-position terminal strip for low impedance or constant voltage operation		
Mounting Points	Pan-tilt mounting bracket included (up to 10.8° down-tilt, ± 55° panning)		
Environmental	IP54 per IEC 60529, designed in accordance with MIL-STD-810G Included ABS plastic rain cover with integrated cable inlet and 1" (25.4mm) knockout for conduit ingress		
Dimensions H x W x D	39.11" x 4.63" x 7.48" (993 x 118 x 190 mm)		
Weight	28 lbs (12.7 kg)		
Finish	Refer to the Technical Drawing (page 3)		
OPTIONS			
Accessories	E200-UMK universal mounting kit E200-SAK stand adapter kit		

AXIAL PROCESSED RESPONSE (dB)⁸

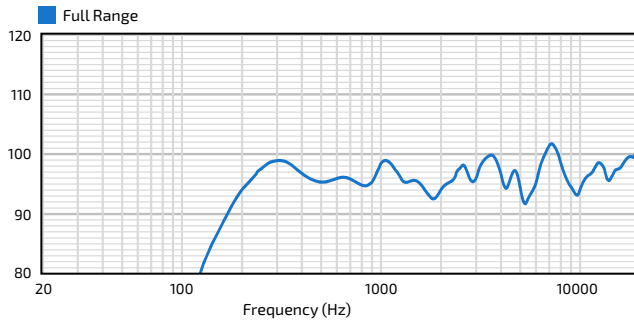

BEAMWIDTH (Degrees)¹²

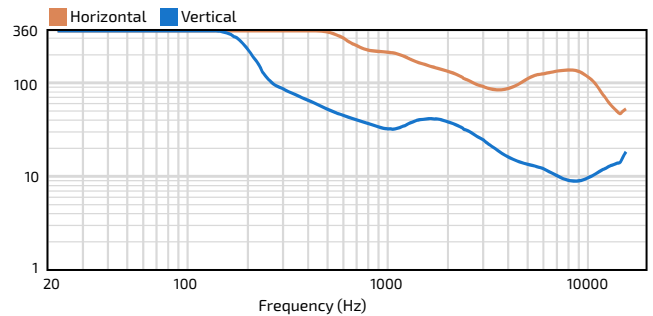

AXIAL SENSITIVITY (dB SPL)⁹

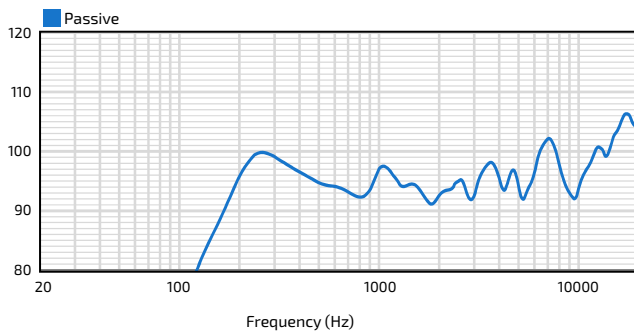

DIRECTIVITY INDEX (dB)¹¹

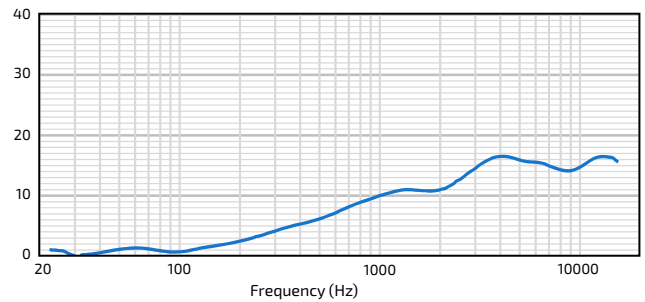

IMPEDANCE (Ohms)

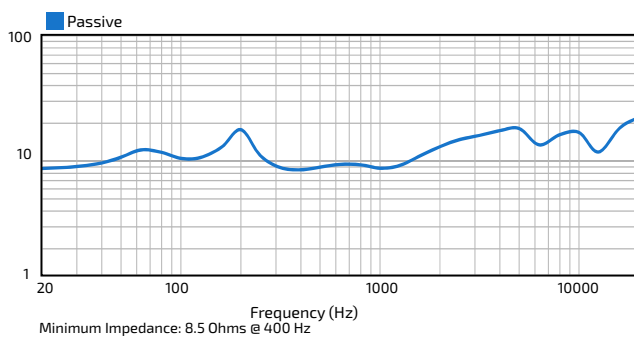

ARCHITECTURAL SPECIFICATIONS

The loudspeaker system shall be a two-way, full-range column array system with twelve 80mm long excursion mylar low frequency transducers and four three-element Compact Ribbon Emulator direct-radiating high frequency transducers. The drivers shall be connected to an integral crossover employing 4-way frequency shaded circuitry, and an HF crossover frequency of 5000 Hz, with dynamic driver protection circuitry. There shall be one eight-terminal barrier strip, and a NL4-type connector on a recessed input panel. The system shall be equipped with a 120W high performance autoformer for use in 70.7V or 100V distributed audio systems, with 120W, 60W, 30W, 15W and 7.5W taps available in 70.7V distributed systems (120W, 60W, 30W and 15W taps available in 100V distributed systems). The paintable enclosure shall be constructed of high-gloss PVC. The front of the enclosure shall be fitted with a powder-coated perforated marine-grade aluminum grille backed with foam or fabric. A pan-tilt mounting bracket is included that will allow the system to have a down-tilt of up to 10.8° and a panning angle of +/- 55°. The system shall have an operating range of 120 Hz to 22 kHz (-10 dB) and a low impedance (8 Ohm) input capability of 51V RMS. The sensitivity on axis at one meter with a power input of 1 Watt shall be 97 dB. The nominal dispersion shall be 140° H x 15° V. Dimensions shall be 39.11 inches (993mm) high, 4.63 inches (118mm) wide and 7.48 inches (190mm) deep, with a loudspeaker weight of 28.0 lbs (12.7 kg).

ENT212

TWO-WAY, COMPACT
COLUMN ARRAY LOUDSPEAKER

TECHNICAL DRAWING / DIMENSIONS / FINISH

H x W x D
39.11" x 4.63" x 7.48"
(993 x 118 x 190 mm)

Unit Weight
28.0 lbs (12.7 kg) loudspeaker and mount

Shipping Weight
33 lbs (15.0 kg)

Grille:
Powder-coated perforated marine-grade aluminum backed with color-matched foam or fabric backing. Black (RAL#9004) or White (RAL#9003)

Enclosure / Finish
Black or White high gloss extruded paintable PVC

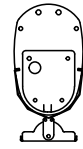
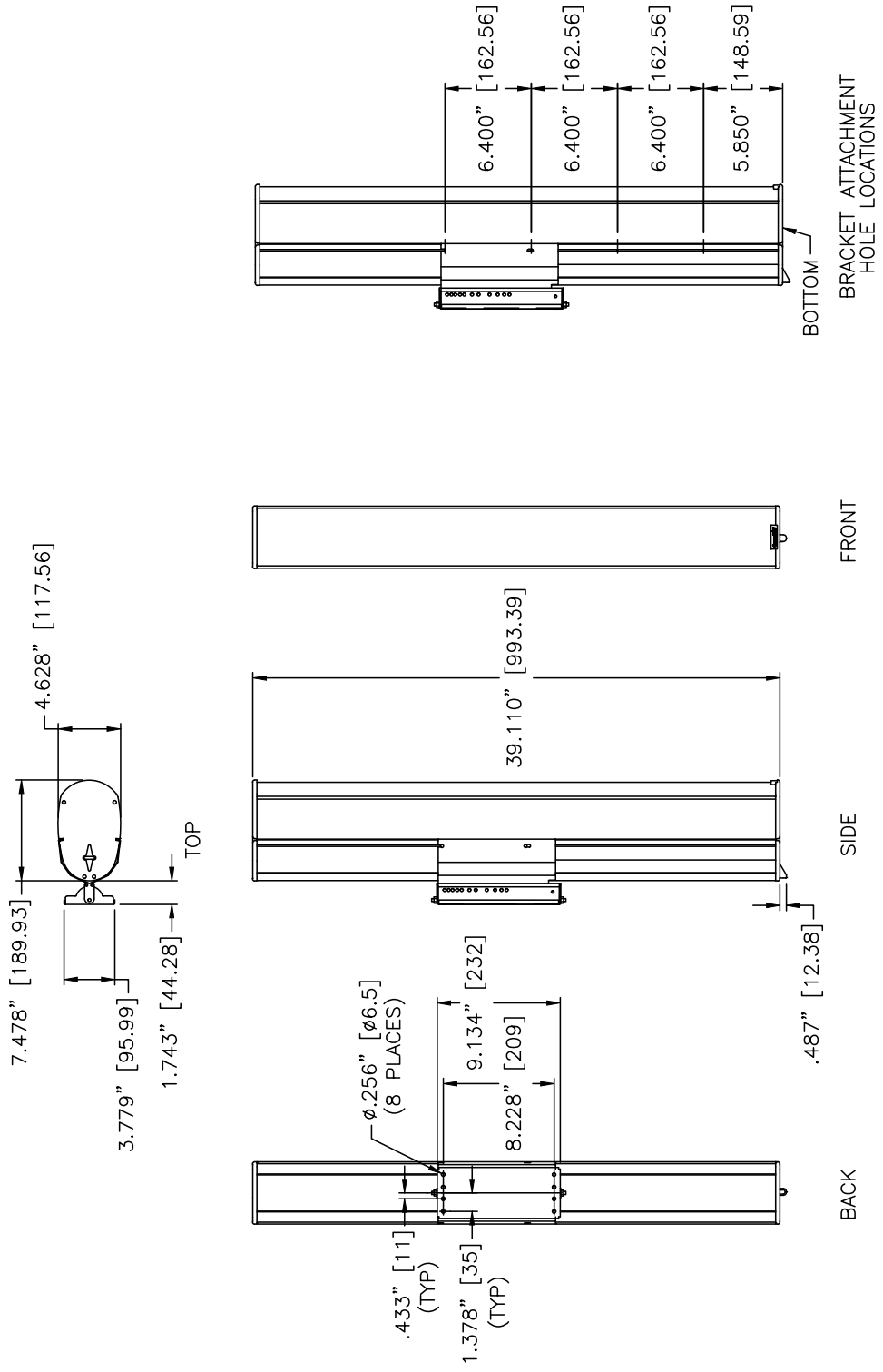

E SERIES Point Source

ENT212

TWO-WAY, COMPACT
COLUMN ARRAY LOUDSPEAKER

CONNECTION DIAGRAMS

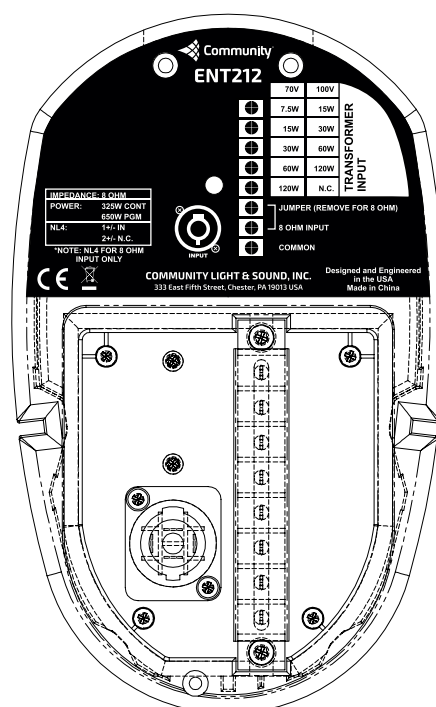
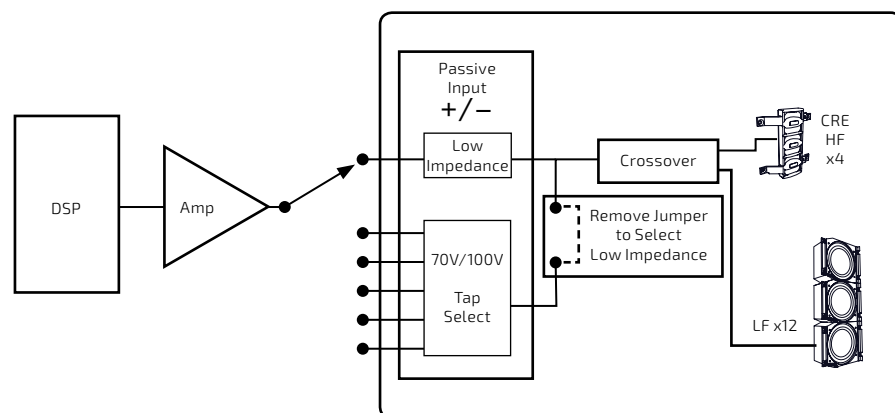

Input panel

NOTES

- PERFORMANCE SPECIFICATIONS** All measurements are taken indoor using a time-windowed and processed signal to eliminate room effects, approximating an anechoic environment, a distance of 6.0 m. All acoustic specifications are rounded to the nearest whole number. An external DSP with settings provided by Community Professional Loudspeakers is required to achieve the specified performance; further performance gains can be realized using Community's dSPEC226 loudspeaker processor with FIR power response optimization.
- OPERATING RANGE** The frequency range in which the on-axis processed response remains within 10dB of the average SPL.
- CONTINUOUS POWER HANDLING** Maximum continuous input voltage (and the equivalent power rating, in watts, at the stated nominal impedance) that the system can withstand, without damage, for a period of 2 hours using an EIA-426-B defined spectrum; with recommended signal processing and protection filters.
- NOMINAL SENSITIVITY** Averaged SPL over the operating range with an input voltage that would produce 1 Watt at the nominal impedance and the averaged SPL over the operating range with a fixed input voltage of 2.83V, respectively; swept sine wave axial measurements with no external processing applied in whole space, except where indicated.
- NOMINAL MAXIMUM SPL** Calculated based on nominal / peak power handling, respectively, and nominal sensitivity; exclusive of power compression.
- EQUALIZED SENSITIVITY** The respective SPL levels produced when an EIA-426-B signal is applied to the equalized loudspeaker system at a level which produces a total power of 1 Watt, in sum, to the loudspeaker subsections and also at a level which produces a total voltage, in sum, of 2.83V to the loudspeaker subsections, respectively; each referenced to a distance of 1 meter.
- EQUALIZED MAXIMUM SPL** The SPL produced when an EIA-426-B signal is applied to the equalized loudspeaker system, at a level which drives at least one subsection to its rated continuous input voltage limit, referenced to a distance of 1 meter. The peak SPL represents the 2:1 (6dB) crest factor of the EIA-426-B test signal.
- AXIAL PROCESSED RESPONSE** The on-axis variation in acoustic output level with frequency of the complete loudspeaker system with recommended signal processing applied. 1/6 octave Gaussian smoothing applied.
- AXIAL SENSITIVITY** The on-axis variation in acoustic output level with frequency for a 1 Watt swept sine wave, referenced to 1 meter with no signal processing. 1/6 octave Gaussian smoothing applied.
- HORIZONTAL / VERTICAL OFF-AXIS RESPONSES** The loudspeaker's magnitude response at various angles off-axis, with recommended signal processing applied in the operating mode which utilizes the largest number of individually amplified pass bands. 1/6 octave Gaussian smoothing applied.
- DIRECTIVITY INDEX** The ratio of the on-axis SPL squared to the mean squared SPL at the same distance for all points within the measurement sphere for each given frequency; expressed in dB. 1/6 octave Gaussian smoothing applied.
- BEAMWIDTH** The angle between the -6dB points in the polar response of the loudspeaker when driven in the operating mode which utilizes the largest number of individually amplified pass bands. 1/6 octave Gaussian smoothing applied.

Data presented on this spec sheet represents a selection of the basic performance specifications for the model. These specifications are intended to allow the user to perform a fair, straightforward evaluation and comparison with other loudspeaker spec sheets. For a detailed analysis of this loudspeaker's performance, please download the GLL file and/or the CLF file from our website: communitypro.com