

V SERIES

Installation and Operation Guide

Models (VERIS 2)

V2-6, V2-6T

V2-8, V2-8T

V2-26, V2-26T

V2-28, V2-28T

V2-1264, V2-1296

V2-1564, V2-1596

V2-3264, V2-3294

V2-3564, V2-3594

V2-212S

V2-215S



IMPORTANT SAFETY INSTRUCTIONS

Always follow these basic safety precautions when using or installing V SERIES loudspeakers and accessories:

- Read these instructions prior to assembly.
- Keep these instructions for reference.
- Heed all warnings.
- Follow all instructions, particularly those pertaining to rigging, mounting, hanging and electrical connections.
- Do not use this apparatus near water.
- Clean only with dry cloth.
- Do not block any ventilation openings. Install in accordance with the manufacturer's instruction.
- Do not install near any heat sources such as radiators, heat registers, stoves, or other apparatus (including amplifiers) that produce heat.
- Only use attachments and accessories that are specified and approved by the manufacturer.

Refer all servicing to qualified service personnel. Servicing is required when the apparatus has been damaged in any way, such as liquid has been spilled or objects have fallen into the apparatus, the apparatus has been exposed to rain or moisture, does not operate normally, or has been dropped.

The terms CAUTION, WARNING, and DANGER may be used in this manual to alert the reader to important safety considerations. If you have any questions or do not understand the meaning of these terms, do not proceed with installation. Contact your local dealer, distributor, or call Community directly for assistance. These terms are defined as:



CAUTION: describes an operating condition or user action that may expose the equipment or user to potential damage or danger.



WARNING: describes an operating condition or user action that will likely cause damage to the equipment or injury to the user or to others in the vicinity.



DANGER: describes an operating condition or user action that will immediately damage the equipment and/or be extremely dangerous or life threatening to the user or to others in the vicinity.

These installation instructions are for use by qualified personnel only. To reduce the risk of fire or electric shock do not perform any servicing other than that contained in the operating instructions unless you are qualified to do so.

RIGGING AND ELECTRICAL SAFETY



IMPORTANT: The loudspeakers described in this manual are designed and intended to be mounted to differing building surfaces using a variety of rigging hardware, means and methods. Installation of loudspeakers should only be performed by trained and qualified personnel. All electrical connections must conform to applicable city, county, state, and national (NEC) electrical codes.



DANGER: All rigging fittings must be fully tightened and secured. Any missing fasteners or parts will compromise the structural integrity of the enclosure and constitute a safety hazard. Do not suspend this loudspeaker unless all fasteners are securely in place!



DANGER: It is possible to experience severe electrical shock from a power amplifier. Always make sure that all power amplifiers are in the "OFF" position and unplugged from an AC Mains supply before performing electrical work.



IMPORTANT: Refer to the sections on installation and connections later in this manual for additional information on rigging and electrical safety.



IMPORTANT: The flat-head hex-drive rigging screws that come installed in each enclosure must either be replaced with rigging brackets and threaded fasteners, or they must be kept in place to seal the enclosure from air leaks. If the rigging fittings do not remain sealed, air leaks will occur in the enclosure that will compromise the low-frequency performance with distortion, reduced output, and premature driver failure.

UNPACKING / INSPECTION

Community V SERIES V2 loudspeakers are engineered and manufactured to be rugged and they are carefully packed in sturdy cartons. However, it is recommended to thoroughly inspect each unit after it has been removed from the packaging, as damage could occur during shipping.

Please note that once the shipment has left your dealer or the Community factory, the responsibility for damage is always borne by the freight company. If damage has occurred during shipping, you must file a claim directly with the freight company. It's very important to contact the freight company as soon as possible after receiving your shipment, as most freight companies have a short time limit within which they will investigate claims. Make sure to save the carton and the packing material, as most claims will be denied if these materials are not retained. Your Community dealer and the factory will try to help in any way they can, but it is the responsibility of the party receiving the shipment to file the damage claim.

It is always a good idea to retain the carton and packing materials, if possible, in the event that the unit may need to be returned to your dealer or distributor for repair in the future.

IN THE CARTON

Each shipping carton contains the following:

- V2 Loudspeaker (fully assembled)
- Information packet
- Models V2-6, V2-8, V2-26, and V2-28 include a yoke-style mounting bracket



DANGER: V SERIES V2 model rigging fittings are rated at a Working Load Limit (WLL) of 100 lbs (45.4 kg) with a 10:1 safety margin. No single rigging fitting should ever be subjected to a load that is greater than this stated limit. Failure to heed this warning could result in injury or death!



CAUTION: Installation of V SERIES loudspeakers should only be performed by trained and qualified personnel. It is strongly recommended that a licensed and certified professional structural engineer (P.E.) approve the mounting. Severe injury and/or loss of life may occur if this product is improperly installed.

OVERVIEW

The ability of V SERIES V2 loudspeakers to meet the needs of a broad range of installation requirements, at affordable price points, is truly unmatched. Venues such as nightclubs, cafés, discotheques, houses of worship, auditoriums, lecture halls, restaurants, theatres, and almost anywhere else that people gather to enjoy music or hear the spoken word, are within the ability of the V2 line to respond with acoustical perfection.

The V2 models excel in applications that require controlled coverage patterns, high-impact power response, and intelligible sonic output. V SERIES loudspeakers are flexible, easy to install, and most importantly, they provide excellent sound quality.

This manual is intended to help you install V SERIES V2 loudspeakers effectively and safely. Additional information can be found on the individual model specification sheets (available from the downloads section of the Community website).

We recommend that you take the time to read the entire manual to insure that your V SERIES installations meet the highest possible standards of performance and safety standards.

The V SERIES V2 line consists of the models briefly described below:

- V2-6 - a 6.5" two-way in a trapezoidal enclosure with rotatable HF horn.
- V2-8 - an 8" two-way in a trapezoidal enclosure with rotatable HF horn.
- V2-26 - a dual 6" two-way in a trapezoidal enclosure with rotatable HF horn.
- V2-28 - a dual 8" two-way in a trapezoidal enclosure with rotatable HF horn.
- V2-12 - a 12" two-way in a trapezoidal enclosure with a choice of 60° x 40° or 90° x 60° horn patterns.
- V2-15 - a 15" two-way in a trapezoidal enclosure with a choice of 60° x 40° or 90° x 60° horn patterns.
- V2-32 - a 12" three-way in a trapezoidal enclosure with a choice of 60° x 40° or 90° x 40° horn patterns. Horn is rotatable.
- V2-35 - a 15" three-way in a trapezoidal enclosure with a choice of 60° x 40° or 90° x 40° horn patterns. Horn is rotatable.
- V2-2125 - a dual 12" subwoofer in a rectangular enclosure.
- V2-2155 - a dual 15" subwoofer in a rectangular enclosure.

V2 loudspeakers may be used in multiples, forming clusters and arrays. Systems may be designed around horizontal splayed arrays, vertical splayed arrays, as well as exploded clusters and distributed configurations. Rigging kits are available from the factory as standard items.

PRODUCT REPRESENTATION

V2 FULL-RANGE (TYPICAL)

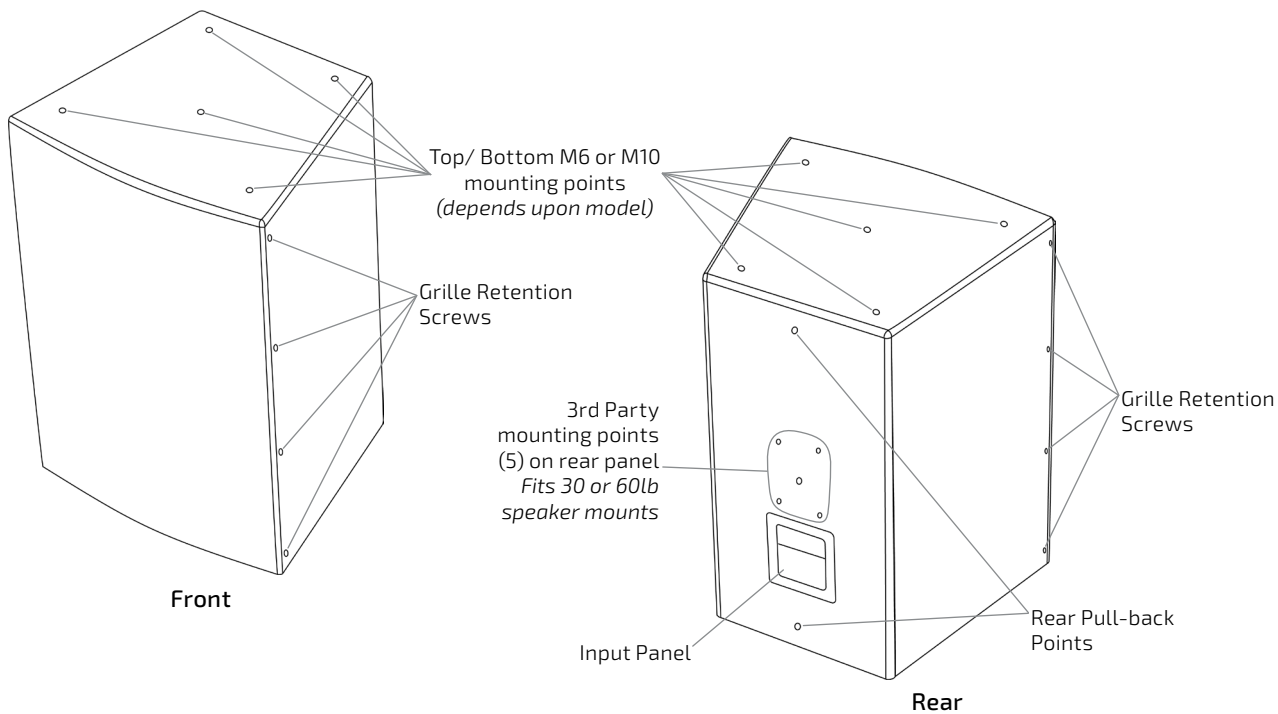

V2 SUBWOOFER (TYPICAL)

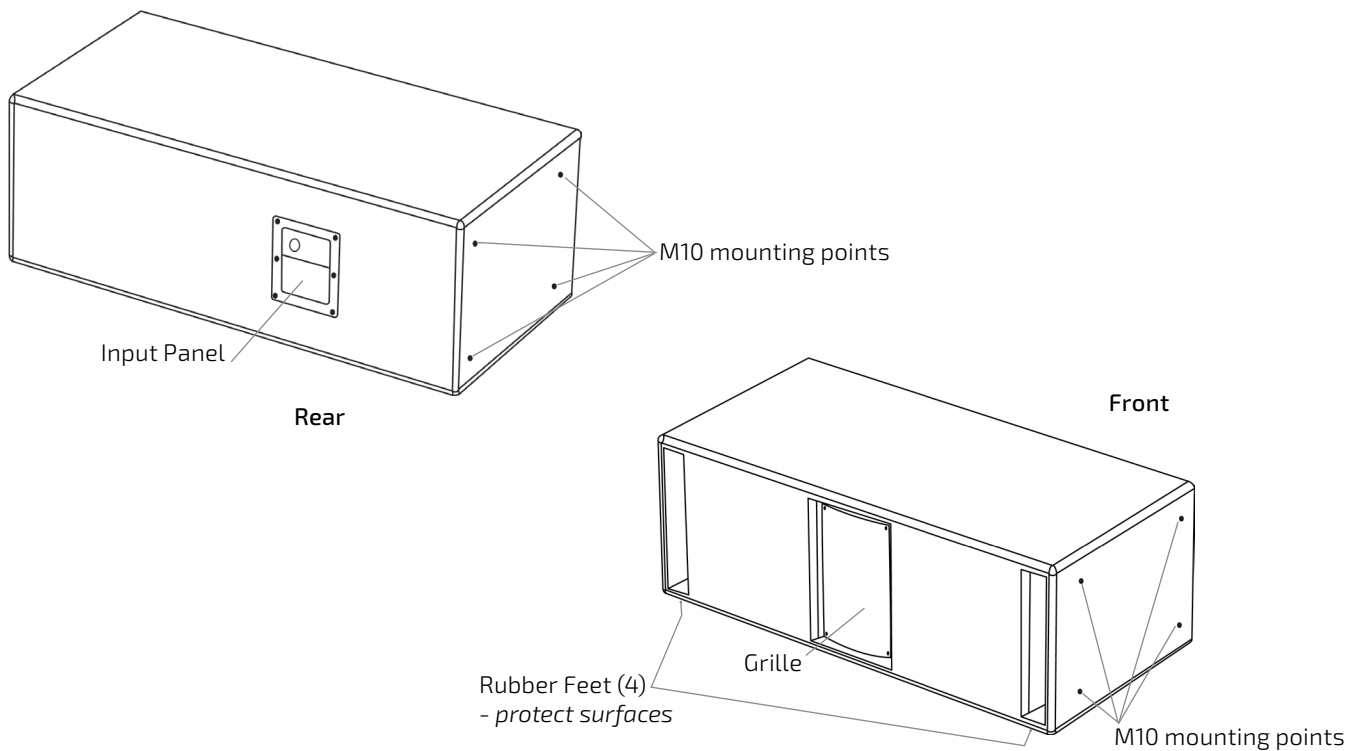

CONNECTIONS AND INSTALLATION

USE THE CORRECT WIRE OR CABLE

The V2 loudspeakers are intended to be connected directly to the amplifier. Most of the V2 models come with two methods of connecting the amplifier to the loudspeaker; a terminal strip and an industry standard NL4-type locking connector. These two connectors are wired in parallel with each other, on all models.

The compact T (transformer) models have a terminal strip connector to select the appropriate tap setting (no NL4-type connector). Refer to Figure 2 for label examples.

If connecting to the terminal strip, terminating the wires with a spade or ring connector (Figure 1a) is recommended for secure connections. The maximum width of the ring or spade lug should be 0.375" (9.5mm), or less. The terminal screws are #8 (M4). The maximum wire size that can be accommodated for bare wire connections is 10 AWG (5.26 mm²).

Note: Wire insulation colors may vary depending upon region or manufacturer. Be consistent with conductor color use throughout the system.

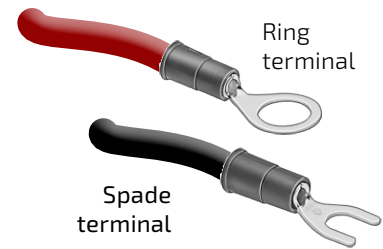

Figure 1a. Wire Connectors

NL4-TYPE CONNECTORS

Terminations may be soldered, or made by means of their built-in screw and pressure clamp (Figure 1b). If using the pressure clamp, it's important to tighten it fully, then to wait about ten minutes (longer is better), then to tighten it again. This is because copper wire flows under pressure. After initially tightening the screw clamp, some minutes later the screw will no longer be as tight due to the effect of the compression on the copper. Typically, only one cycle of "tighten – wait – re-tighten" is required for a secure connection.

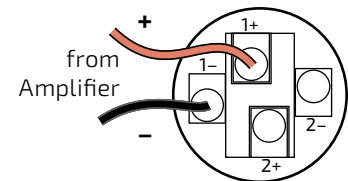

Figure 1b. NL4-Type Connector



DANGER: When wiring the amplifier(s) to the loudspeaker(s), always power-down the amplifier(s) and disconnect their AC Mains plug(s). Many high power amplifiers can deliver enough voltage and current to cause a harmful or lethal electric shock.

Shocks from very low frequencies, such as kick drums, can cause the human heart to stop beating at relatively low power levels.



WARNING: After wiring the amplifier(s) to the loudspeaker(s), first power up all devices that are upstream of the amplifier, such as mixers, equalizers, compressor/limiters, etc., before powering-up the amplifier. This is to avoid passing any clicks or pops that may originate in the upstream devices to the loudspeakers. The amplifier should initially be powered-up with its gain controls turned all the way down. After making sure that a continuous signal is present, such as music source playing, slowly raise the level of the gain controls to establish that the wiring has been installed correctly. Only then should the loudspeaker be operated at normal output levels.



IMPORTANT: All electrical installation connections for loudspeaker lines are subject to all applicable governmental building and fire codes. The selection of appropriate electrical hardware to interface with the V SERIES loudspeaker lies solely with the installation professional. Community recommends that an appropriately licensed engineer, electrician, or other qualified professional identify and select the appropriate conduit, fittings, wire, etc. for the installation.

CONNECTIONS AND INSTALLATION

CONNECTION: INPUT PANELS



Example of a typical input panel

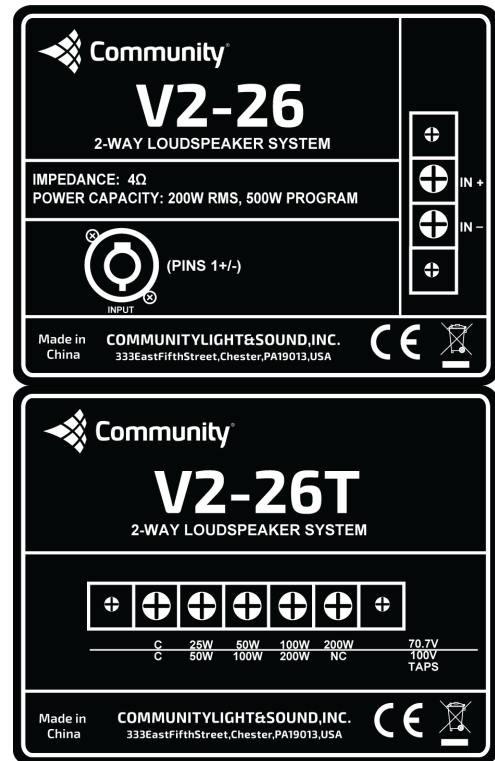

V2 Input Label examples
(V2-26, V2-26T shown)

Figure 2. Input panel and label examples



CAUTION: Be sure to carefully observe polarity when wiring your loudspeakers. If one loudspeaker is wired with the opposite polarity from another loudspeaker, acoustic cancellation will occur. The result will be less acoustic power output than if only one loudspeaker were used by itself.

IMPORTANT: All technical drawings with dimensions, mounting points, etc. are available as a pdf, dwg or dxf file from the downloads section of the website. The technical drawing is also represented on the spec sheet (download from website). V SERIES models can be installed using the accessories available from Community. Installation instructions will accompany each of those accessories.

COMMISSIONING THE SYSTEM

Commissioning is the process of optimizing the performance of the system after it has been installed. There are several steps in commissioning. First is verifying the proper operation of every system component, and then adjusting system gains and levels.

The last step in system commissioning is known as system equalization or "voicing." Equalization is the process of adjusting the frequency response of the system to optimize voice intelligibility or musical sound quality (or both). Note that V SERIES loudspeakers are factory voiced to optimize their speech intelligibility and musical sound quality. For this reason, many designers find they can minimize overall system equalization and still achieve excellent voice intelligibility and musical sound quality without extensive EQ. However, in the end this is a function of the room acoustics. A large, highly reverberant room will require more attention than a small, dry acoustic space.

When equalizing a V2 loudspeaker system the following points should be kept in mind to achieve the best results and to avoid damaging the drivers.

1. Use only small amounts of equalization. In particular, do not boost frequencies by more than about 3 dB. Cutting frequencies by more than 3 dB of attenuation is acceptable, but bear in mind that extreme frequency cuts will usually result in less than optimum performance, unless carefully derived by use of a precision measurement system in a room that has excessive resonance. *Rule of Thumb: less is usually more.*
2. Do not attempt to boost any frequencies below 100 Hz with a graphic equalizer. Note that with the recommended high-pass filter, moderate amounts of boost from a simple bass control are acceptable.

HIGH-PASS FILTERS

We strongly encourage the use of an external, active high-pass filter to protect the cone drivers from excessive low-frequency excursion. A high-pass filter will eliminate the potential of low-frequency modulation from wind noise, turntable rumble, stage vibration, and other causes that result in a poorly defined and 'muddy' bass response. Additionally, a high-pass filter will avoid wasting amplifier power by keeping the amplifier from attempting to reproduce frequencies below the loudspeaker's intended operating range.

The recommended high pass filter settings are available on each model's "spec sheet" available on Community's website. The DSP settings for all V SERIES models are also available in the "downloads" section of the Community website.

RIGGING / SUSPENSION AND SAFETY

The terms "rigging", "flying" and "suspension" are often used interchangeably in describing methods of installing loudspeaker systems at elevated positions.

IMPORTANT NOTES ON RIGGING LOUSPEAKERS

There are three areas of responsibility for rigging loudspeakers. The first is the building structure. Always consult with the building architect or structural engineer to assure the ability of the structure to support the loudspeaker system. The second area of responsibility is the loudspeaker itself. Community certifies its loudspeaker systems and rigging accessories for suspension when they are properly installed according to our published guidelines. The third area of responsibility is everything between the loudspeaker and the building structure and the actual process of installation. The installing contractor assumes this responsibility. Loudspeaker rigging should be performed only by certified rigging professionals using certified rigging hardware chosen for the specific application. Prior to installation, the contractor should present a rigging plan, with drawing and detailed parts list, to a licensed structural engineer (P.E.) or architect for written approval.

 **DANGER:** Some of the loudspeakers described in this manual are may be suspended using a variety of rigging hardware, means, and methods. It is essential that all installation work involving the suspension of these loudspeaker products be performed by competent, knowledgeable persons who understand safe rigging practices. Severe injury and/or loss of life may occur if these products are improperly suspended.

 **DANGER:** All rigging fittings must remain sealed with the included flat-head Allen screws or they must be fitted with properly rated optional mounting hardware. Any missing fasteners will compromise the structural integrity of the enclosure and constitute a safety hazard. Do not suspend this loudspeaker unless all fasteners are securely in place!

 **WARNING - NON-COMMUNITY RIGGING HARDWARE:** Non-Community hardware used for rigging the V SERIES subwoofers must be certified by the supplier for this use and must be properly rated for safety.



IMPORTANT: All rigging fittings should remain sealed, or air leaks will occur in the enclosure that can compromise the low-frequency performance with distortion and reduced output.



WARNING: V2 rigging fittings are rated at a Working Load Limit of 100 lbs (45.4kg) with a 10:1 safety margin. No single rigging fitting should ever be subjected to a load that is greater than 100 lbs. Failure to heed this warning could result in injury or death!

ACCESSORIES



CEILING MOUNT KIT

Model CMKIT

The Ceiling Mount Kit creates a hang point from a ceiling surface. The CMKIT consists of a ceiling mount bracket and a bolt that fastens to a U-yoke bracket or to one of several optional loudspeaker brackets. It can be used with all full-range V2 loudspeakers.

Note: The yoke is sold separately for V2 models 12/15/32/35. The yoke is included with V2 models 6/26/8/28.

VERTICAL FLYING KIT

Model VFKIT

The VFKIT for V2-12/15/32/35 full-range loudspeakers allows two same-size enclosures to be flown at 45 and 60 degree splay angles. To vertically array 3 same-size enclosures, use 2 VFKIT's. To vertically array 4 same-size enclosures, use 3 VFKIT's. Four eyebolts are included with each VFKIT.



ACCESSORIES (CONTINUED)

YOKE BRACKETS

Models VB-Y12, VB-Y15, VB-Y32, VB-Y35

Optional yoke brackets for the larger full-range models V2 12/15/32/35 allow for direct horizontal mounting of the loudspeaker to a wall or ceiling. This unique yoke bracket also permits vertical mounting with a selection of 0°, 10°, or 20°, of either upward or downward inclination.

Note: Yoke brackets are included with compact V2 models V2-6/8/26/28. Refer to the supplementary instruction sheet included with these models for more information and installation instructions.



VERSATILT BRACKET

Model VB-VST

The VB-VST allows for precise installation of a single full-range V2 loudspeaker from the ceiling. It includes a rotational device, a hang bracket that fastens to the top or bottom of the enclosure, and a ceiling mount bracket. It is designed to be used with any 12" or 15" two-way or three-way full-range V2 loudspeaker. An M10 eyebolt is included for use as a safety point.

TILTING BRACKET

Model VB-TILT

The TILT bracket allows for precise angling of a V2 loudspeaker. The VB-TILT is a two-part rotational device that can be used to fasten one enclosure to another; to fasten an enclosure to the CMKIT Ceiling Mount Kit; to fasten to a yoke bracket permitting one loudspeaker to be angled in relation to another in two axes. The VB-TILT can be used with all full-range V2 enclosures.

Note: Yokes are sold separately for models V2-12/15/32/35. A yoke is included with all V SERIES models V2-6/26/8/28.



EYEBOLT KIT

Model Nos. M10EYBLTKIT, M6EYBLTKIT

Suspend your V2 loudspeakers safely and easily. Use the 10mm M10EYBLTKIT with V2-12/15/32/35; use the 6mm M6EYBLTKIT with the smaller V2-6/8/26/28. Four eyebolts are included in each kit.

VERTICAL YOKE KITS

Model Nos. VB-VY6/VY8/VY26/VY28/VY12/VY15/VY32/VY35

The Vertical Yoke Kit allows for precise installation of a single full-range V2 loudspeaker from an over-head yoke.



TROUBLESHOOTING / SERVICE

Should you have a problem with your VERIS 2 loudspeaker(s), find the symptom and follow the associated WHAT TO DO instructions below. Please note that a particular symptom may have several possible causes.

SYMPTOM	PROBABLE CAUSE	WHAT TO DO
High distortion, low output, or no output from any or all drivers.	Faulty connection to the loudspeaker. Possible solder joint failure on crossover card.	Using an ohmmeter, check the continuity of the wiring to the loudspeaker. If the wiring is OK, remove the input panel and check all solder joints on the crossover and the wiring to the drivers. Visually inspect solder joints as cold joints may only malfunction under high current. Repair as needed.
Distortion from the loudspeaker at higher volume levels.	Too little amplifier power.	If the power rating of the amplifier is too low, it will clip at higher volume levels. Reduce the volume level or use a more powerful amplifier.
Distortion from the loudspeaker at moderate to high volume levels.	Driver is malfunctioning.	Using a sine wave oscillator or wide range program at moderate levels, listen to each driver to isolate the problem. Replace as needed.
Low or no output from the low-frequency driver.	Low-frequency driver, crossover, or amplifier is malfunctioning.	Test and replace as needed.
Low or no output from the low-frequency driver.	Mis-wired NL4-compatible locking connector.	Check wiring and correct as needed.
Low or no output from the mid-frequency driver (applies to three-way systems only).	Mid-frequency driver, crossover, or amplifier is malfunctioning.	Test and replace as needed.
Low or no output from the high-frequency driver.	High-frequency driver, crossover, or amplifier is malfunctioning.	Test and replace as needed.
Low volume level.	System gain is too low.	Check to make sure that the audio signal to the amplifier is high enough to drive it properly. Check all volume/level controls and gain switches in the system including the amplifier input attenuator.
Low volume level.	Signal or speaker wire connection is shorted.	Make sure the signal and input wire connections inside all system connectors are not shorted or open. Even one small wire strand shorting the +/- signal terminals together anywhere in the system can cause this problem.
No sound.	Amplifier is not on or loudspeaker is disconnected.	Check that amplifier is turned on and that loudspeaker is properly connected to the amplifier.
No sound or very low volume.	No audio signal.	Check that all the audio equipment in the signal chain is powered on and that all gain controls are in the proper position.
Noises from the loudspeaker (buzzes or rattles).	Grille or hardware is loose.	Make sure the front grille screws are securely seated and that any external mounting hardware is tightened or secured from vibrating.
Noises from the loudspeaker (buzzes or rattles).	Driver is malfunctioning.	Using a sine wave oscillator or wide range program at moderate levels, listen to each driver to isolate the problem. Replace as needed.
Sound cuts in and out at high levels.	The crossover protection circuits have been activated.	This usually means that the loudspeaker is being constantly overdriven and the crossover protection circuits are reducing the power to the loudspeaker as a protective measure. Reduce the volume level to the loudspeaker.
Sound cuts in and out.	Bad connection.	Check all connections and cabling for shorts or loose connections. Even one small wire strand shorting the +/- signal terminals anywhere in the system can cause this problem.
Sudden 6 dB loss in sound level.	The crossover protection circuits have been activated.	This usually means that the loudspeaker is being constantly overdriven and the crossover protection circuits are reducing the power to the loudspeaker as a protective measure. Reduce the volume level to the loudspeaker, to restore full dynamic range.

SERVICING V2 LOUDSPEAKERS

Any driver service required can be accomplished from the front of the enclosure by removing the screws around the edge of the grille. Crossovers and connections may be accessed by removing the rear connector plate. For warranty repair, contact Community directly or ask us for the location of your nearest Authorized Service Center.

PERFORMANCE AND SPECIFICATIONS

USE A DIGITAL SIGNAL PROCESSOR

For best performance, loudspeaker protection and system longevity, a digital signal processor (DSP) must be used with all V SERIES loudspeakers. Community's dSPEC226 processor(s) and Resyn® software contain all of the information (high pass filters, limiters, factory tunings) and DSP settings to fully optimize your system. For more information on installing and operating your V SERIES loudspeakers, please refer to Community's website at communitypro.com, or contact our Technical Applications Group (TAG) at tagteam@communitypro.com, or by phone at 610-876-3400 or toll-free (within the US and Canada) at 800-523-4934.

SPECIFICATIONS AND INFORMATION

Full product specifications and current documentation (manuals, sales literature) is available at communitypro.com. Additional technical information to assist you in operating and optimizing your system or understanding more about loudspeaker operation is also available on the website or by contacting the Technical Applications Group (TAG).

WARRANTY INFORMATION

TRANSFERABLE WARRANTY “(LIMITED)” VALID IN THE USA ONLY

The V SERIES loudspeakers are designed and backed by Community Professional Loudspeakers. For complete warranty information within the USA please refer to www.communitypro.com/warranty-statement. Please call 610-876-3400 or visit the website to locate your nearest Authorized Field Service Station. For Factory Service call 610-876-3400. You must obtain a Return Authorization (R/A) number prior to the return of your product for factory service.

WARRANTY INFORMATION AND SERVICE FOR COUNTRIES OUTSIDE THE USA

To obtain specific warranty information and available service locations for countries other than the United States of America, contact the authorized Community Distributor for your specific country or region.

Note: Every effort has been made to insure that the information contained in this manual was complete and accurate at the time of printing. However, due to ongoing technical advances, changes or modifications may have occurred that are not covered in this manual. The latest version is available at communitypro.com.

©2018 Community Professional Loudspeakers V2_Manual v: 25JUN2018

Community Professional Loudspeakers
333 East Fifth Street, Chester, PA 19013-4511 USA
Phone (610) 876-3400 • Fax (610) 874-0190
www.communitypro.com

